

ABT-HC-PL-49

Product Data Sheet

49 CF Premium Laboratory Glass Door Refrigerator

Product Description

ABS Premium Lab Refrigerators deliver superior cooling to laboratory environments. Engineered with variable speed compressors (VSCs), these units feature ultra-quiet operation and significant energy savings. VSCs optimize energy consumption by self-adjusting to cooling demands. These compressors also deliver enhanced system performance and provide a longer lifespan than other compressor variations.

Enjoy the uniformity and speed of microprocessor temperature control and a full array of alarms to safeguard your products. Unit controllers also come with a battery backup to keep your data safe. Upgrade your laboratory environment with these premium refrigerators and welcome energy savings, noise reduction, smooth operation, and improved system performance to your work environment.

Images



Certifications



General Description and Application

|                                  |                                                                                   |
|----------------------------------|-----------------------------------------------------------------------------------|
| Storage capacity (cu. ft)        | 49                                                                                |
| Door                             | Double Swing Glass Right and Left Hinged Door(s)                                  |
| Shelves                          | Ten adjustable shelves with guard rail on back                                    |
| Drawers                          | Optional pull-out drawers available                                               |
| Mounting and installation        | 4 preinstalled swivel casters, front casters locking                              |
| Interior lighting                | Shielded, switched LED lighting, full coverage, balanced spectrum                 |
| Airflow Management               | Forced Air technology, patent pending                                             |
| External probe access            | Rear wall port (3/4" dia.                                                         |
| Insulation                       | Cabinet is foamed-in-place with EPA compliant high density urethane foam          |
| Exterior materials               | White powder coated steel                                                         |
| Access control                   | Key Lock                                                                          |
| General warranty                 | Two (2) years parts and labor warranty                                            |
| Compressor warranty              | Seven (7) years compressor warranty                                               |
| Product Weight (lbs)             | 581                                                                               |
| Shipping Weight (lbs)            | 700                                                                               |
| Rated Amperage                   | 4.5 Amps                                                                          |
| Power Plug/Power Cord            | NEMA 5-15 plug                                                                    |
| Facility Electrical Requirement  | 110-120V AC: 15 A (minimum)                                                       |
| Agency Listing and Certification | ETL, C-ETL listed and certified to UL471 standard, hydrocarbon refrigerant safety |

Performance

|                                             |                      |
|---------------------------------------------|----------------------|
| Uniformity <sup>1</sup> (Cabinet air)       | ±1.2                 |
| Stability <sup>2</sup> (Cabinet air)        | ±1.0                 |
| Maximum temperature variation (Cabinet air) | ±1.6                 |
| Stability <sup>3</sup> (Simulator ballast)  | Non-applicable       |
| Stability <sup>3</sup> (Simulator bag)      | Non-applicable       |
| Temperature Rise after Short Door Openings  | Non-applicable       |
| Recovery after Short Door Openings          | Non-applicable       |
| Energy Consumption (KWh/day)                | 1.47                 |
| Average Heat Rejection (BTU/hr)             | 465                  |
| Noise Pressure Level (dBA)                  | 38 or less installed |
| Pull down time to nominal operating temp    | 70 min               |

Temperature Probes

| Probe | Ave | Min | Max |
|-------|-----|-----|-----|
| 1     | 3.3 | 2.4 | 4.5 |
| 2     | 3.8 | 3.2 | 4.6 |
| 3     | 3.8 | 3.2 | 4.3 |
| 4     | 3.1 | 2.4 | 4.1 |
| 5     | 3.7 | 3.2 | 4.3 |
| 6     | 3.8 | 3.2 | 4.4 |
| 7     | 3.8 | 3.4 | 4.4 |
| 8     | 4.0 | 3.6 | 4.6 |
| 9     | 5.0 | 4.4 | 5.6 |
| 10    | 4.0 | 3.5 | 4.5 |
| 11    | 4.1 | 3.4 | 4.8 |
| 12    | 4.0 | 3.6 | 4.5 |
| 13    | 4.3 | 4.0 | 4.6 |
| 14    | 4.9 | 4.5 | 5.3 |
| 15    | 3.8 | 3.3 | 4.4 |
| Bal   | N/A | N/A | N/A |
| Bag   | N/A | N/A | N/A |

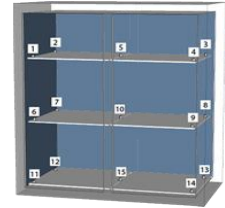

Temperature Charts

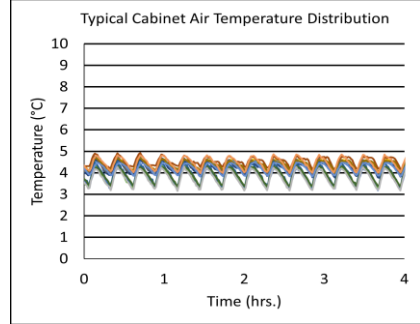
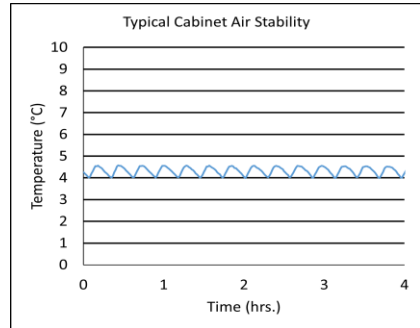

Performance data acquired at 22°C ambient, 4°C nominal set point in an empty cabinet with drawers using validation ballast probes, during stabilized steady state operation and a DAQ sampling rate of one measurement every 10 seconds

1 - Uniformity is defined as the maximum variance in temperature across all probes at any point in time over the testing period

2 - Stability is defined as the maximum variance in temperature experienced by any single probe over the testing period

3 - Data per Energy Star test results or equivalent testing and calculation. Heat rejection based on daily averages, not continuous operation. Performance exceeds Energy Star requirements.

| Refrigeration System |                                                                  |
|----------------------|------------------------------------------------------------------|
| Compressor           | Hermetic, variable speed (VSC). Rated speed range: 1300-4000 rpm |
| Refrigerant          | EPA SNAP compliant, R600a                                        |
| Condenser            | Anti-fouling tube and grid design, ultra-quiet multi-speed fan   |
| Evaporator           | Fin and tube design, high efficiency fan                         |
| Defrost              | Cycle optimized, zero energy                                     |

| Controller, Configuration, Alarms and Monitoring |                                                                                                                                                                                                                                                                                                                                                                                                                                                                                                                                                                                                                                                                                                           |
|--------------------------------------------------|-----------------------------------------------------------------------------------------------------------------------------------------------------------------------------------------------------------------------------------------------------------------------------------------------------------------------------------------------------------------------------------------------------------------------------------------------------------------------------------------------------------------------------------------------------------------------------------------------------------------------------------------------------------------------------------------------------------|
| Controller technology                            | Proportional Integral Derivative (PID) microprocessor with LCD display                                                                                                                                                                                                                                                                                                                                                                                                                                                                                                                                                                                                                                    |
| Battery Backup                                   | 24V high-capacity battery, controller, all alarms active, temperature monitoring DAQ and event logging active on battery backup                                                                                                                                                                                                                                                                                                                                                                                                                                                                                                                                                                           |
| Display technology                               | Non-applicable                                                                                                                                                                                                                                                                                                                                                                                                                                                                                                                                                                                                                                                                                            |
| Digital Communication                            | RS-485 (MODBUS)                                                                                                                                                                                                                                                                                                                                                                                                                                                                                                                                                                                                                                                                                           |
| Data Transfer                                    | USB port for data transfer and software updates                                                                                                                                                                                                                                                                                                                                                                                                                                                                                                                                                                                                                                                           |
| Chart Recorder                                   | Non-applicable                                                                                                                                                                                                                                                                                                                                                                                                                                                                                                                                                                                                                                                                                            |
| Adjustable Temperature Range                     | 1°C to 10°C                                                                                                                                                                                                                                                                                                                                                                                                                                                                                                                                                                                                                                                                                               |
| External alarm connection                        | State switching remote alarm contacts                                                                                                                                                                                                                                                                                                                                                                                                                                                                                                                                                                                                                                                                     |
| Alarms                                           | Alarm logging (last 100 entries) with Visual and audible indicators: Power failure, Temperature sensor failure, Battery voltage monitor and replacement, High / Low temperature, Door ajar.                                                                                                                                                                                                                                                                                                                                                                                                                                                                                                               |
| Controller probe                                 | Bottle with glass bead thermal media                                                                                                                                                                                                                                                                                                                                                                                                                                                                                                                                                                                                                                                                      |
| Disclaimers                                      | Performance data acquired at 22°C ambient, 4°C nominal set point in an empty cabinet with drawers using validation ballast probes, during stabilized steady state operation and a DAQ sampling rate of one measurement every 10 seconds<br><br>1 - Uniformity is defined as the maximum variance in temperature across all probes at any point in time over the testing period<br>2 - Stability is defined as the maximum variance in temperature experienced by any single probe over the testing period<br>3 - Data per Energy Star test results or equivalent testing and calculation. Heat rejection based on daily averages, not continuous operation. Performance exceeds Energy Star requirements. |

| Dimensions |             |             |              |                  |                        |
|------------|-------------|-------------|--------------|------------------|------------------------|
|            | Width (in.) | Depth (in.) | Height (in.) | Door Swing (in.) | Total open Depth (in.) |
| Exterior   | 54"         | 35 3/4"     | 81 1/2"      | 25 1/4"          | 59 1/8"                |
| Interior   | 49 1/8"     | 26 1/2"     | 59"          |                  |                        |

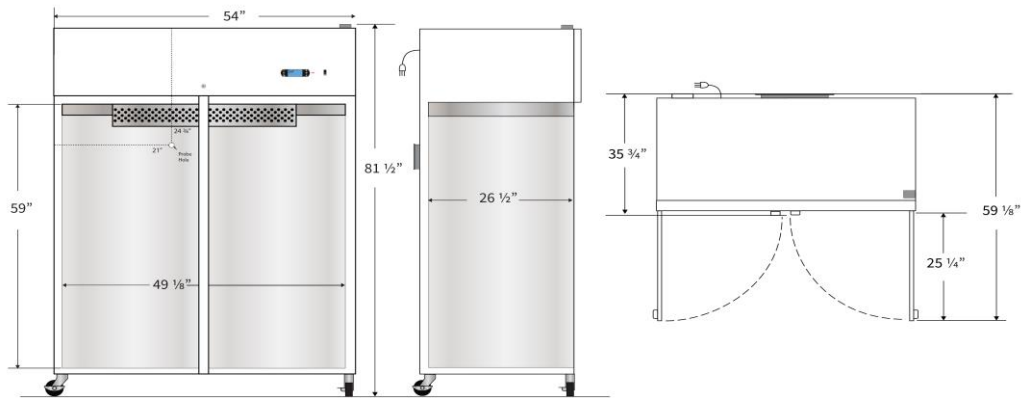

| Contact           |                                       |                                                                                                    |
|-------------------|---------------------------------------|----------------------------------------------------------------------------------------------------|
| Customer Service  | 800-648-4041 Option 3                 | <a href="mailto:customerservice@horizonscientific.com">customerservice@horizonscientific.com</a>   |
| Technical Service | 800-648-4041 Option 5, Parts Option 4 | <a href="mailto:technicalservice@horizonscientific.com">technicalservice@horizonscientific.com</a> |

Rev\_06162023