



## Compressor-cooled incubator ICP450

Do you require different ramps for incubating, breeding or storing? Do you need a larger chamber volume and at the same time quick temperature changes?



With the help of our model selection, with dimensioned model sketches and extensive technical data for download, you can find the right cooled incubator for your needs. For small volumes and for work predominantly in the proximity of the ambient temperature, the Memmert Peltier-cooled incubator is recommended. Flexibility and technical features of our appliances meet all possible needs. Put us to the test!

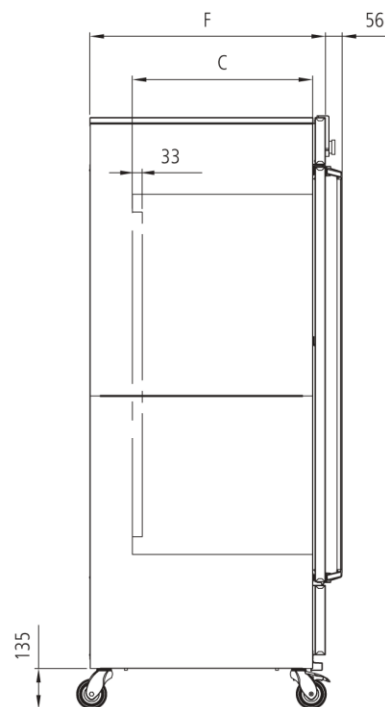
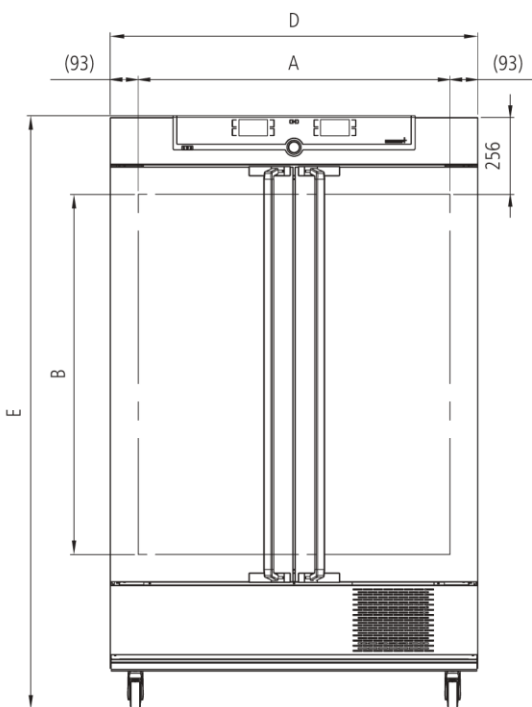

## Control of standard components

<b>Control</b>	<b>COCKPIT</b>	adaptive multifunctional digital PID-microprocessor controller with 2 high-definition TFT-color displays
<b>Temperature</b>		2 Pt100 sensors Class A in 4-wire-circuit, mutually monitoring and taking over the performance at the same temperature value
<b>Timer</b>		Digital backwards counter with target time setting, adjustable from 1 minute to 99 days

## Temperature

		from -12°C up to +60°C (optimum performance of cooling aggregate at an ambient temperature of +16°C up to +32°C)
<b>resolution of display for setpoint and actual temperature values</b>		0.1°C

## Control technology

<b>adjustable parameters</b>		temperature (Celsius or Fahrenheit), fan speed, program time, time zones, daylight savings time
<b>Function Setpoint</b>	<b>WAIT</b>	the process time does not start until the set temperature is reached
<b>Language setting</b>		German/English/Spanish/French
<b>Calibration</b>		three freely selectable temperature values

## Ventilation

<b>Fan</b>		forced air circulation in working chamber adjustable from 10 to 100 % in 10 % steps
------------	--	---

## Communication

<b>Programming</b>		AtmoCONTROL software on a USB stick for programming, managing and transferring programs via Ethernet interface or USB port
<b>Documentation</b>		program stored in case of power failure

## Safety

<b>Autodiagnostic system</b>		for fault analysis
<b>Alarm</b>		audible and visual
<b>Temperature control</b>		over- and undertemperature monitor TWW, protection class 3.3 or adjustable temperature limiter TWB, protection class 2, selectable on display
<b>AutoSAFETY</b>		additionally integrated over- and undertemperature protection "ASF", automatically following the set point value at a preset tolerance range, alarm in case of over- or undertemperature, heating is switched off in case of overtemperature, compressor in case of undertemperature
<b>Temperature control</b>		mechanical temperature limiter TB, protection class 1 according to DIN 12880 to switch off the heating approx. 10°C above nominal temperature

### Heating concept

no drying-up of the load caused by the cooling device due to separation of thermal jacket from interior

energy-saving use of CFC-free cooling/heating system (refrigerant R134a)

highly efficient automatic defrosting system

air jacket heating system for gentle all-around heating

### Standard equipment

**Door** fully insulated stainless steel doors with 2-point locking (compression door lock)

**Door** inner glass doors

**Internals** 2 stainless steel grids

**Scope of delivery** incl. works calibration certificate for +10°C and +37°C

**Housing** rear zinc-plated steel

**Installation** on lockable castors

### Stainless steel interior

$w_{(A)} \times h_{(B)} \times d_{(C)}$ : 40.9" x 28.4" x 23.6"

Volume 449 l

Max. loading of chamber: 441 lbs

### Textured stainless steel casing

$w_{(D)} \times h_{(E)} \times d_{(F)}$ : 48.2" x 63.5" x 30.9"

### Electrical data

115 V (+/- 10%), 50/60 Hz / approx. 10.4 amps

230 V (+/- 10%), 50/60 Hz / approx. 5.0 amps

### Packing/shipping data

**the appliances must be transported upright**

**Customs tariff number** 8419 8998

**Country of origin** Federal Republic of Germany

**WEEE-Reg.-No.** DE 66812464

Dimensions approx incl. carton B x H x T: 52.4" x 66.9" x 41.3"

Net weight approx. 479 lbs

Gross weight carton approx. 622 lbs