

Product datasheet

CaptairFlow 321

Clean air enclosure

Providing an ultra-clean, dust free enclosure

CaptairFlow vertical laminar flow cabinets are designed for tissue culture, non-pathogenic biological samples, food microbiology, cell culture, and semi - conductor assembly:

Dust free workstation

- Protection against dust contamination
- Internal dust - free air quality achieved by high efficiency particulate filter (s) (HEPA H14 or ULPA U17)
- Optional carbon filter to protect samples from VOCs present in the laboratory room
- Class 5 air quality in the enclosure according ISO 14644-1

UV-C Germicidal Lamp

- To sterilize the interior and contents before usage to prevent cross-contamination from the previous experiment
- This UV lamp switches off automatically if the operator opens the lower door by accident during decontamination

Easy to Clean

- Seamless worktop with smooth corners (available in TRESPA®TopLab^{PLUS} or Stainless steel 304 L)
- Non-porous material

Ergonomic Design

- 4 models available for your handlings with large openings for easy access to your work
- Slanted sash provides an ergonomic position for comfort and productivity
- High luminosity, internal LED lighting > 800 lux



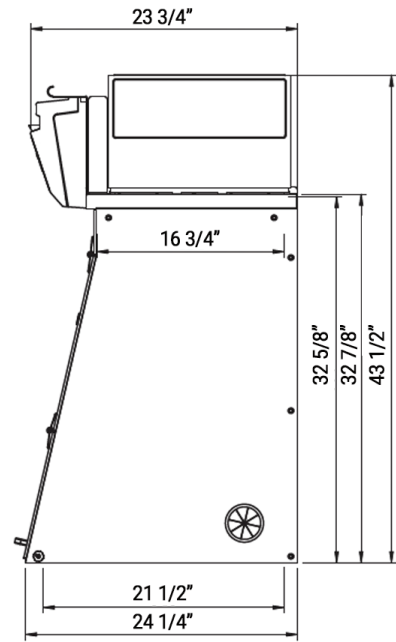
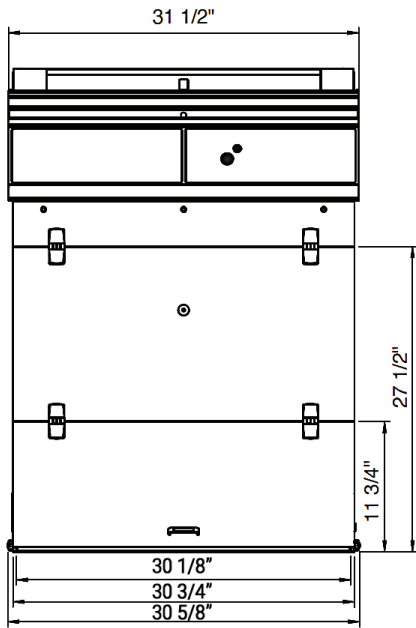

Please add 5 7/8" between the last filter and the ceiling to allow good air recirculation and to replace filters easily.

Work surfaces with built in spill tray

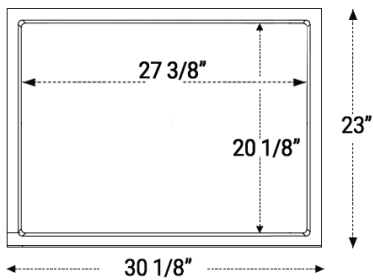

TRESPA®TopLab^{PLUS}

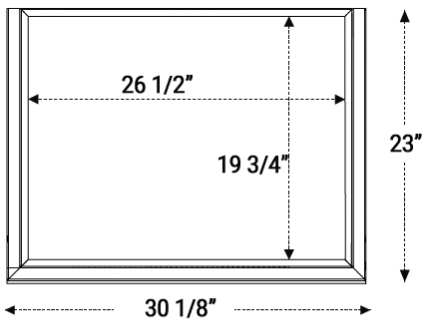

Stainless steel 304 L

Benchcap: fixed work bench

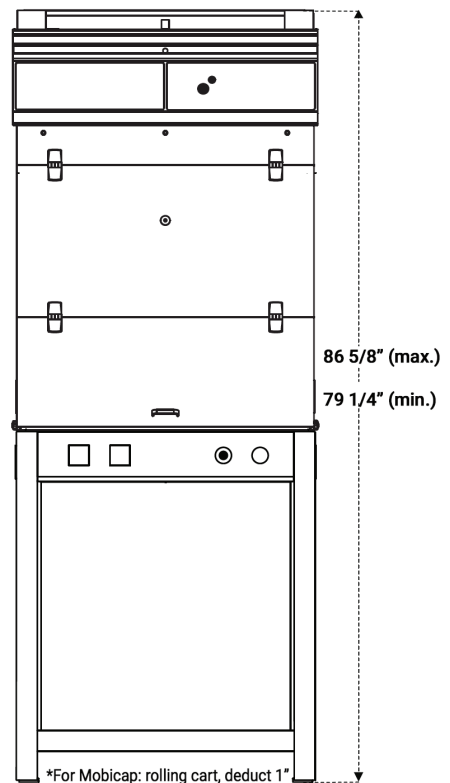

Designed with you in mind: Our filtration column can be configured for your specific application requirements.

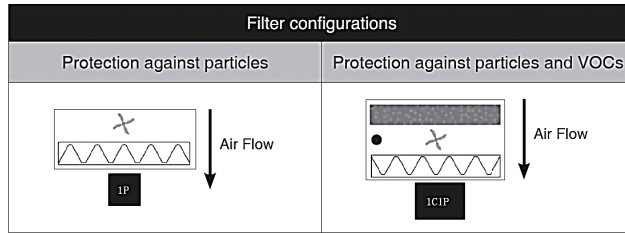

 Ventilation

● Molecode : Automatic alarm to detect filter breakthrough

Filter types:

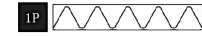

Particulate filtration for powders



Carbon filtration for gases and vapors

Model	1P	1C1P
Safety Standards	NF EN 61010 - CE Marking - EN 1822:1998 (HEPA H14 & ULPA U17 Filters) Air quality within the enclosure: ISO Class 5* EN 14644-1 standard	
External Width	31 5/8"	
External Depth	24 1/4"	
External Height	43 1/2" - 50 1/8"	
Internal Width	30 1/8"	
Internal Depth (min./max)	19 3/4" - 21 1/2"	
Internal Height	32 5/8"	
Voltage/Frequency (V-Hz)	100-240 / 50-60	
Air Face Velocity (fpm)	68	
Air Flow (CFM)	188	88
Power Consumption	55	35
Decibel Level (dBA)	59	49
Side and front panels	Chemical resistant acrylic	
Structure	Corrosion resistant electro-galvanized steel coated with anti-acid polymer	
Filtration Module	Polypropylene	

Filtration

Particulate filter (1P)	HEPA H14: This filtration technology traps particles larger than 0.1 µm with 99.995% efficiency according to the MPPS method set forth in the EN 1822-1 standard. ULPA U16: This filtration technology traps particles larger than 0.1 µm with 99.999995% efficiency according to the MPPS method set forth in the EN 1822-1 standard.
Carbon Filter	Adding a carbon filter to your enclosure allows protection of your samples from VOCs. AS filter: For organic vapors
Carbon filtration for gases and vapours	Following filtration column configuration (see table above)
Particulate pre-filter	Protect particulate filters from dust contained in the laboratory environment (only for 1P version)

Features

Internal Lighting	LED - 1P 44 - 6000k 800 lux
Connectivity	RJ45 cable connection to view and change workstation settings (cable included)
Anemometer	Monitors a drop in pressure that indicates pre-filter or filter replacement is required
Side panel utility ports	2 per unit - to allow electrical cables and/or fluid lines to enter the enclosure with ease
UV Light	Located on back panel - 15W - wave length: 254nm

Accessories

Benches	Rolling cart (Mobicap) or fixed bench (Benchcap)
Shelves	Internal metal sliding shelf (only for Benchcap)
Worktop	TRESPA®TopLab ^{PLUS} , Glass or 304L Stainless Steel
Molecode S	Automatic detection of VOC filter breakthrough



The Erlab Research and Development laboratory

About Erlab

Since 1968, **Erlab** has been a specialist, inventor and world leader in **ductless, zero-emission filtering fume hoods for laboratories** to provide total safety in chemical handling.

1 Erlab filtration

We provide technologies to protect laboratory staff from inhaling chemicals. This is made possible thanks to our Research and Development (R&D) department, which has continuously improved our filtration technology for more than 50 years. That's why, in 2009, we invented the ERLAB ABOVE label for tried and tested filtration technology.

2 The AFNOR NF X 15-211: 2009 standard

Erlab's filtration technology conforms to the NF X 15-211: 2009 standard, the industry's most demanding standard for molecular filtration, developed by a committee of independent scientists and specialized manufacturers.

This text imposes performance criteria linked to:

- Filtration efficiency
- Containment efficiency
- Air face velocity
- Documentation: chemical listing

3 The ESP program

A set of three services included with the purchase of each device designed to ensure your safety.

 **eVallQuest** Risk analysis – Determination of protection needs – Determination of ergonomic needs.

 **VallPass** Certified installation – Total safety for handling.

 **VallGuard** Ongoing monitoring – Preventative and maintenance inspections – Device reconfiguration based on protection needs – Development of handling.

4 Flex technology

The combination of molecular and particulate filtration technologies allows a single device to meet laboratories' protection needs. This innovation from Erlab's R&D department offers unprecedented flexibility, versatility and value. A single device can be reconfigured over time and easily reassigned to other applications.

5 Smart technology

Smart technology is a simple and innovative means of communication that improves safety. This technology uses a light and sound signal to indicate the user's level of protection. The advantages of the technology are:

- 1/ Light pulsation: Real-time communication via LED light pulses intuitively alerts the user to the device's operating status.
- 2/ Simplicity: One-touch activation.
- 3/ Detection system: The exclusive detection system continuously monitors filtration performance.
- 4/ Built-in monitoring: This service provides direct access to the status, settings and history of your device.

CaptainFlow 321_V02_05_2026_EN - Erlab USA - Technical data are not contractual. Erlab® DFS SAS reserves the right to modify the present document without prior notice.