

ABT-HC-2186-TS

Images



Product Description

Transform your laboratory with these industry-leading ultra-low temperature freezers. Protect your samples with steel-insulated inner doors for ultimate temperature retention down to -86°C. Experience highly efficient variable speed compressors for energy savings and enhanced system performance. Conduct advanced data logging through intuitive touchscreen control—track real-time temperature readings, export data, and capture trends with just a few taps. Dual voltage compatibility ensures installation flexibility, with each unit including both 115V and 230V power cords under a single part number. You can also rest secure knowing your samples are guarded by a full array of alarms—no more surprise temperature excursions. As a finishing touch, you'll benefit from natural hydrocarbon refrigerants for sustainability, energy efficiency, and long-term cost savings. Together, these features are designed to push boundaries and harness the full potential of the modern ULT.

Certifications



General Description and Application

Storage capacity (cu. ft.)	21 Cu. Ft. Capacity
Door	One solid exterior door, right hinged, not reversible; Five insulated inner doors
Shelves	Four adjustable, stainless steel (standard), tested to 160 lbs. (optional configurations available)
Box Capacity	Qty. 400 2" boxes (25 UF442 racks)
Baskets	Non-applicable
Mounting	Four heavy duty swivel casters with locks
Interior lighting	Non-applicable
Airflow management	Non-applicable
External probe access	1/2" diameter port; access from back of unit to interior left side
Insulation	Foamed-in-place EPA compliant high density urethane foam
Exterior materials	Powder coated Steel
Access Control	Key lock on exterior door handle
General warranty	Five (5) year parts and labor warranty
Compressor Parts Warranty	Seven (7) year compressor warranty
Product Weight (lbs)	680
Shipping Weight (lbs)	780
Rated Amperage	10A (120V), 6A (240V)
Power Plug/Power Cord	Two detachable cords supplied, min. 8' length: 120V (NEMA 5-15 Plug) and 240V (NEMA 6-15 Plug)
Facility Electrical Requirement	Dual voltage 110-120V 15A (minimum) or 208-240V AC 15A (minimum)
Agency Listing and Certification	UL/C-UL listed. Certified to UL 60335-2-89 safety standard

Refrigeration System

Refrigerant	R290 / R170
Compressor:	Two ea. variable speed hermetic reciprocating
Condenser	Tube and Fin design, EC fan, easy clean removable filter
Evaporator	Cold wall (Natural convection)

Controller, Configuration, Alarms and Monitoring

Controller technology	Microprocessor with color touchscreen (11in) input and display, C° or F°
Digital Communication:	4-20mA output for temperature monitoring
Adjustable Temperature Range	-86°C to -50°C
External alarm connection	State switching remote alarm contacts
Battery Backup:	12V high capacity battery for controller and touchscreen display: temperature monitoring, alarms, and event logging active
Energy Consumption (kWh/day/CUFT)	As low as 0.48 kWh/day/cu.ft.
Warm-up times:	180+ minutes -80°C to -50°C
Vacuum Relief Port:	Includes heated vacuum relief port for pressure equalization reducing wait times between door openings
Average heat rejection (BTU/h):	1627 BTU/h
Alarms	Audible and Visual Alarms: customizable sounds and volumes; mute with visual persistence; ring-back functionality re-engages audible alarm after pre-set delay if alarm condition persists. Adjustable delays for door, temperature, power loss.
Disclaimers	Indoor use only, +18C to +26C (+65F to +78F), <70% RH. Specifications are subject to change. Backup battery maintains display, data logging, and alarms. Cooling capability is not maintained without external generator or LN2/CO2 injection.

Optional Accessories

Removable storage racks, Precision fit rack system (in place of shelves), storage boxes, Wi-Fi data logger, additional shelves, additional chamber temperature (sample) probe.

**Dimensions**

	Width (in.)	Depth (in.)	Height (in.)	Door Swing (in.)	Total open Depth (in.)
Exterior	43.3"	36.3"	79.6"	37.3"	73.6"
Interior	29.1"	23"	45.96"		

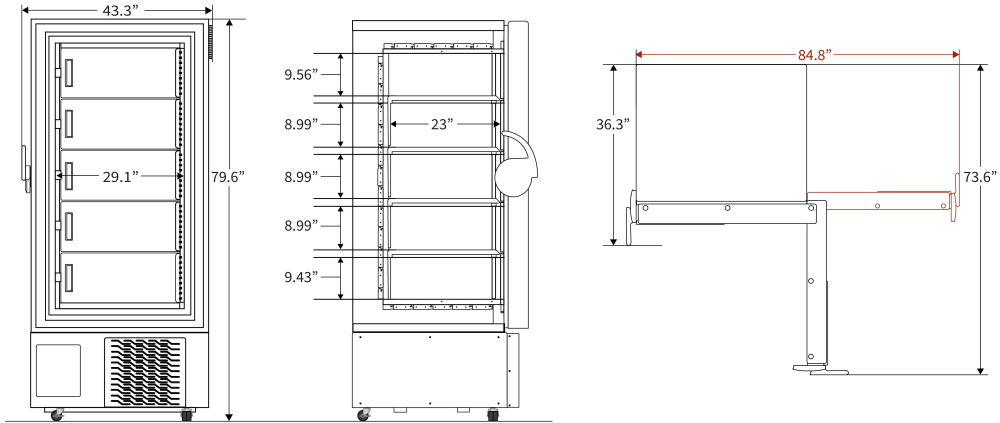

**Contact**

Customer Service  
Technical Service

800-648-4041 Option 3  
800-648-4041 Option 5, Parts Option 4

customerservice@horizonscientific.com  
technicalservice@horizonscientific.com

Rev\_06022025