



## Product datasheet

# CaptairFlow 391

Clean air enclosure

### Providing an ultra-clean, dust free enclosure

CaptairFlow vertical laminar flow cabinets are designed for tissue culture, non-pathogenic biological samples, food microbiology, cell culture, semi - conductor assembly:

#### Dust free workstation

- Protection against dust contamination
- Internal dust - free air quality achieved by high efficiency particulate filter (s) ( HEPA H14 or ULPA U17 )
- Optional carbon filter to protect samples from VOCs present in the laboratory room
- Class 5 air quality in the enclosure according ISO 14644-1

#### UV-C Germicidal Lamp

- To sterilize the interior and contents before usage to prevent cross-contamination from the previous experiment
- This UV lamp switches off automatically if the operator opens the lower door by accident during decontamination

#### Easy to Clean

- Seamless worktop with smooth corners (available in TRESPA®TopLab<sup>PLUS</sup> laminate or Stainless steel 304 L)
- Non-porous material

#### Ergonomic Design

- 4 models available for your handlings with large openings for easy access to your work
- Slanted sash provides an ergonomic position for comfort and productivity
- High luminosity, internal LED lighting > 800 lux



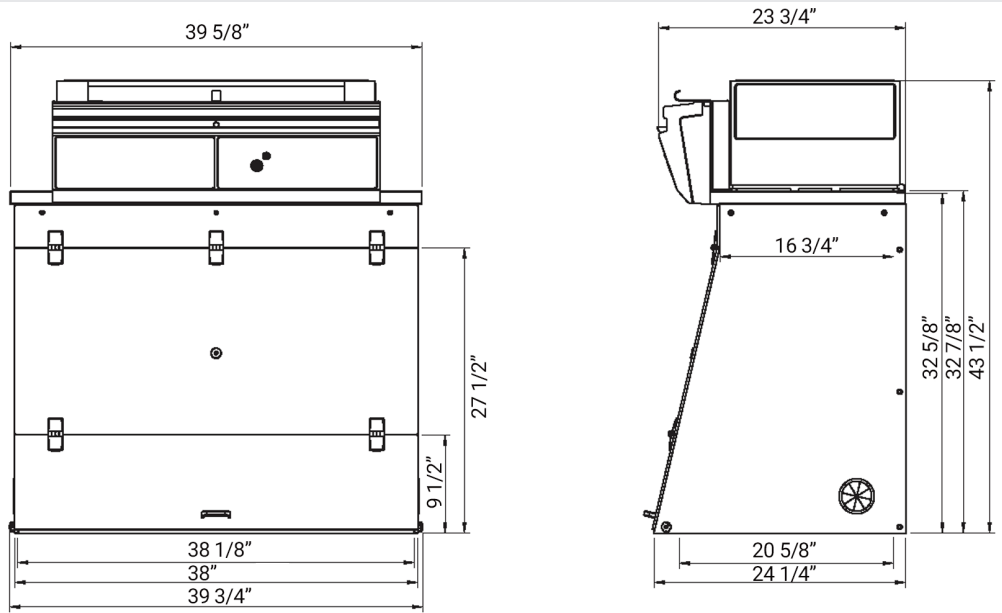

Please add 5 7/8" between the last filter and the ceiling to allow good air recirculation and to replace filters easily.

**Work surfaces with built in spill tray**

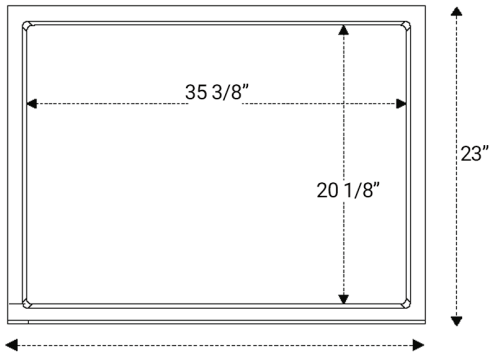

**TRESPA® TopLab<sup>PLUS</sup>**

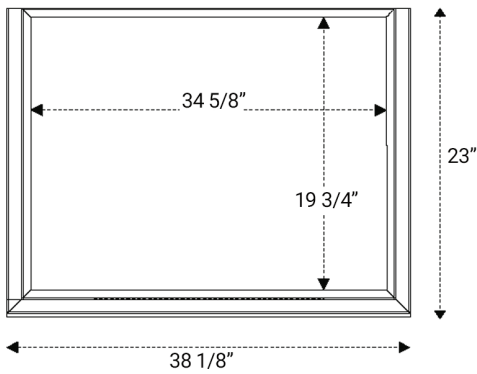

**Stainless steel 304 L**

**Benchcap: fixed work bench**

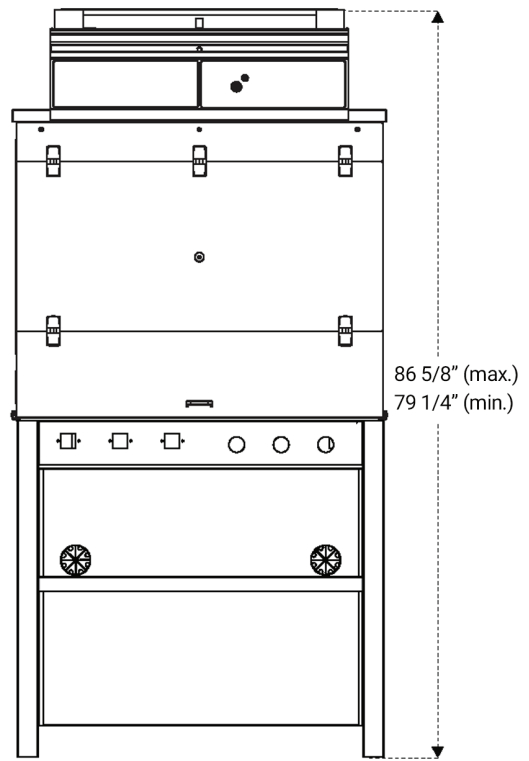

\*For Mobicap: rolling cart, deduct 1"

Designed with you in mind: Our filtration column can be configured for your specific application requirements.

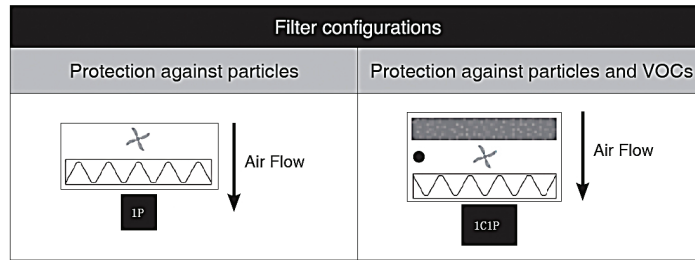

✦ Ventilation

● Molecode : Automatic alarm to detect filter breakthrough

**Filter types:**



**Particulate filtration for powders**



**Carbon filtration for gases and vapors**

Model	1P	1C1P
<b>Safety Standards</b>	NF EN 61010 - CE Marking - EN 1822:1998 (HEPA H14 & ULPA U16 Filters) Air quality within the enclosure: ISO Class 5* EN 14644-1 standard	
<b>External Width</b>	39 3/4"	
<b>External Depth</b>	24 1/4"	
<b>External Height</b>	43 1/2" - 50 7/8"	
<b>Internal Width</b>	38 1/8"	
<b>Internal Depth</b>	19 3/4" - 20 5/8"	
<b>Internal Height</b>	32 5/8"	
<b>Voltage/Frequency (V-Hz)</b>	100-240 / 50-60	
<b>Air Face Velocity (fpm)</b>	68	
<b>Air Flow (CFM)</b>	203	88
<b>Power Consumption</b>	55	40
<b>Decibel Level (dBA)</b>	62	52
<b>Side and front panels</b>	Chemical resistant acrylic	
<b>Structure</b>	Corrosion resistant electro-galvanized steel coated with anti-acid polymer	
<b>Filtration Module</b>	Polypropylene	

## Filtration

<b>Particulate filter (1P)</b>	HEPA H14: This filtration technology traps particles larger than 0.1 µm with 99.995% efficiency according to the MPPS method set forth in the EN 1822-1 standard. ULPA U16: This filtration technology traps particles larger than 0.1 µm with 99.99995% efficiency according to the MPPS method set forth in the EN 1822-1 standard.
<b>Molecular Filter (optional)(1C)</b>	Adding a carbon filter to your enclosure allows protection of your samples from VOCs. AS filter: For organic vapors
<b>Particulate pre-filter</b>	Protect particulate filters from dust contained in the laboratory environment (only for 1P version)

## Features

<b>Worktop</b>	TRESPA®TopLab <sup>PLUS</sup> , Glass or 304L Stainless Steel
<b>Internal Lighting</b>	LED-IP 44 - 6000K 850 lux
<b>Connectivity</b>	RJ45 cable connection to view and change workstation settings (cable included)
<b>Anemometer</b>	Monitors a drop in pressure that indicates pre-filter or filter replacement is required
<b>Side panel utility ports</b>	2 per unit - to allow electrical cables and/or fluid lines to enter the enclosure with ease
<b>UV Light</b>	Located on back panel - 15W - wave length: 254nm

## Accessories

<b>Benches</b>	Rolling cart (Mobicap) or fixed bench (Benchcap)
<b>Shelves</b>	Internal metal sliding shelf (only for Benchcap)



The Erlab Research and Development laboratory

# About Erlab

Since 1968, **Erlab** has been a specialist, inventor and world leader in **ductless, zero-emission filtering fume hoods for laboratories** to provide total safety in chemical handling.

## 1 Erlab filtration

We provide technologies to protect laboratory staff from inhaling chemicals. This is made possible thanks to our Research and Development (R&D) department, which has continuously improved our filtration technology for more than 50 years. That's why, in 2009, we invented the ERLAB ABOVE label for tried and tested filtration technology.

## 2 The AFNOR NF X 15-211: 2009 standard

Erlab's filtration technology conforms to the NF X 15-211: 2009 standard, the industry's most demanding standard for molecular filtration, developed by a committee of independent scientists and specialized manufacturers.

This text imposes performance criteria linked to:

- Filtration efficiency
- Containment efficiency
- Air face velocity
- Documentation: chemical listing

## 3 The ESP program

A set of three services included with the purchase of each device designed to ensure your safety.

 **eVallQuest** Risk analysis – Determination of protection needs – Determination of ergonomic needs.

 **VallPass** Certified installation – Total safety for handling.

 **VallGuard** Ongoing monitoring – Preventative and maintenance inspections – Device reconfiguration based on protection needs – Development of handling.

## 4 Flex technology

The combination of molecular and particulate filtration technologies allows a single device to meet laboratories' protection needs. This innovation from Erlab's R&D department offers unprecedented flexibility, versatility and value. A single device can be reconfigured over time and easily reassigned to other applications.

## 5 Smart technology

Smart technology is a simple and innovative means of communication that improves safety. This technology uses a light and sound signal to indicate the user's level of protection. The advantages of the technology are:

- 1/ Light pulsation: Real-time communication via LED light pulses intuitively alerts the user to the device's operating status.
- 2/ Simplicity: One-touch activation.
- 3/ Detection system: The exclusive detection system continuously monitors filtration performance.
- 4/ Built-in monitoring: This service provides direct access to the status, settings and history of your device.