

ABT-VS-LS-16

Product Description

These laboratory refrigerators are designed for reliable and cost-effective cold storage. This model features ultra-low energy consumption and energy efficient natural refrigerants. Using microprocessor temperature technology, this unit delivers precise temperature monitoring and control. It offers essential security features, including a keyed door lock and temperature alarms, along with remote alarm contacts. Enjoy durable powder-coated steel construction, glass door transparency, and adjustable inner shelving to optimize your workflow. All features are designed to heighten performance and efficiency in your lab.

Images



Certifications



General Description and Application

Storage capacity (cu. ft)	16 Cu. Ft.
Door	One (1) swing glass door, self-closing, right hinged, not reversible, magnetic door gasket
Shelves	Four (4) adjustable shelves (adjustable in 1/8" increments)
Mounting and installation	Swivel casters - locking front casters
Interior lighting	LED interior lights are safety shielded and switch controlled
External probe access	Probe access port (3/4") on rear wall
Insulation	Cabinet is foamed-in-place with EPA compliant high density urethane foam
Exterior materials	White powder coated steel
Access control	Keyed door lock; compatible with optional digital lock (including Pyxis, Omnicell, and AcuDose RX)
General warranty	One (1) years parts and labor warranty
Compressor warranty	Seven (7) years compressor warranty
Product Weight (lbs)	243
Shipping Weight (lbs)	290
Rated Amperage	2 Amps
Power Plug/Power Cord	NEMA 5-15 plug
Facility Electrical Requirement	110 - 120V AC, 15A breaker, NEMA 5-15 receptacle
Agency Listing and Certification	ETL, C-ETL listed. Meets or exceeds Energy Star v2.0 for Laboratory Refrigerators. Official listing pending - see energystar.gov

Refrigeration System	
Compressor	Hermetic
Refrigerant	EPA SNAP compliant R600a Isobutane (Hydrocarbon natural refrigerant)
Condenser	Tube and grid, high efficiency fan forced air
Evaporator	Fin and tube, high efficiency fan forced air
Defrost	Off-cycle defrost, no heat added

Controller, Configuration, Alarms and Monitoring	
Controller technology	Microprocessor temperature controller, C/F switchable, resolution is 0.1C/0.2F
Max temp variation - cabinet air (°C):	+/- 2.5 °C
Energy consumption (KWh/day):	<.9 KWh/day Meets or exceeds Energy Star v2.0 for Laboratory Refrigerators.
Stability - simulator ballast (°C):	+/- 0.5
Average heat rejection (BTU/h):	< 250 BTU/h
Display Technology	Digital Temperature Display
Noise pressure level (dBA):	40 dBA or less installed
Pull down time to nominal operating temp:	< 30 min (empty)
Adjustable Temperature Range	2°C to 15°C
External alarm connection	Remote alarm contacts
Display Probe	Product simulator bottle with glass bead media
Alarms:	Audible and visual high/low temperature alarms, remote alarm contacts
Disclaimers:	Refrigerator requires a minimum 2" of clearance at back and sides of the unit for proper ventilation
Performance Note	Max temperature variation based on an empty chamber at steady state using 15 bare (unweighted) thermocouple probes. Product loading, door openings, and ambient conditions will affect performance. Stability of simulator ballast based on bottle probe provided with the unit located center of empty chamber at steady state, no door openings

Dimensions					
	Width (in.)	Depth (in.)	Height (in.)	Door Swing (in.)	Total open Depth (in.)
Exterior	25"	28.875"	79"	21.5"	50.375"
Interior	20.375"	20.375"	48.75"		

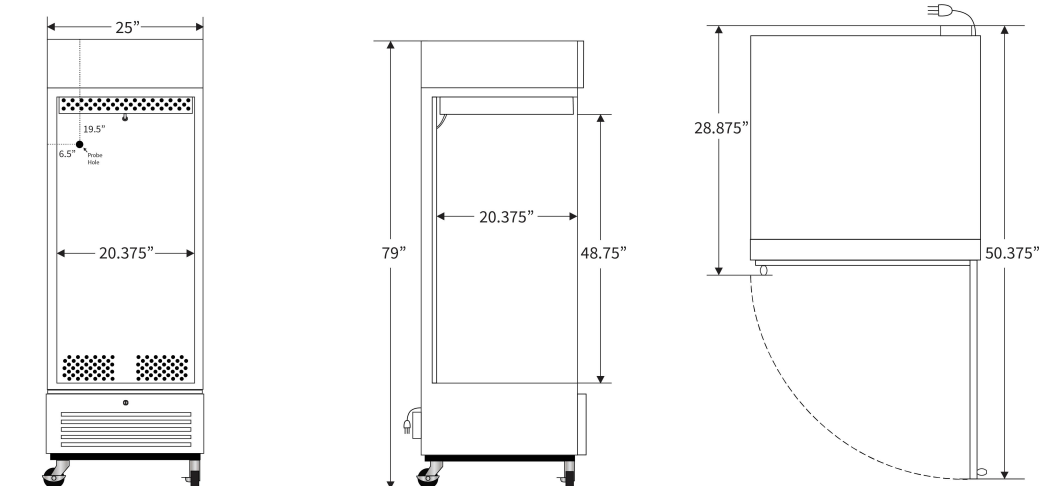

Contact		
Customer Service	800-648-4041 Option 3	customerservice@horizontscientific.com
Technical Service	800-648-4041 Option 5, Parts Option 4	technicalservice@horizontscientific.com

Rev_11.14.2025