

# 8 Steps to a Clean Balance and 5 Solutions to Keep It Clean



Cleaning a balance is important to ensure accurate results and promote long equipment life.

A clean balance is a first step towards safe and accurate weighing and is the most important action to prolong instrument life. Furthermore – and even more important – cleaning increases user safety and reduces the risk of cross-contamination.

This paper imparts knowledge about cleaning methods and agents, and gives you an instruction on how to clean a balance in 8 easy steps. In addition, five solutions will be discussed on how to avoid making your balance dirty in the first place.

# 1. Cleaning is Essential

If you work in a laboratory, then you know that ensuring its cleanliness has a significant impact on both operator safety and cross-contamination risk.

Keeping a balance clean is important. It can:

- Minimize cross-contamination risk
- Enhance user safety
- Increase operating reliability, and
- Reduce equipment failure rates.

Each of these points can represent a significant source of expense for your lab, whether in rework, health costs, or equipment service and replacement costs. Keeping balances clean is a great first step towards reducing these costs.

This paper will cover all aspects of balance cleaning including:

- How to clean various balance components
- Which cleaning agents are appropriate
- How to avoid making your balance dirty
- How intelligent solutions eliminate spills altogether.

Many of the recommendations made in this paper apply to balances made by any manufacturer. Certain specifics of METTLER TOLEDO balances will be covered. When in doubt, the manual that came with your balance is the place to start for information on cleaning and maintenance.

Essentially, cleaning can be quick and easy with appropriate methods and know-how.

## Definitions

**Cleaning:** Physical removal of foreign material, e.g. dust, soil, organic material such as: secretions, excretions and microorganisms. Cleaning generally removes rather than kills microorganisms. It is accomplished with water, detergents and mechanical action.

**Decontamination:** Removal of microorganisms, radioactive substances or hazardous material to leave an item safe for further handling.

**Disinfection:** Inactivation of disease-producing microorganisms. Disinfection does not destroy bacterial spores. Disinfectants are used on inanimate objects in contrast to antiseptics, which are used on living tissue. Disinfection usually involves chemicals, heat or ultraviolet light. The nature of chemical disinfection varies with the type of product used.

**Sterilization:** Destruction of all forms of microbial life including bacteria, viruses, spores and fungi. Items should be cleaned thoroughly before effective sterilization can take place.

## 2. Which Cleaning Agents Should I Use?

**Depending on the laboratory, different risks and potential for contamination exist.**

In chemical and pharmaceutical laboratories, the main risk is the potential for exposure to harmful chemicals or active substances, either by inhalation, ingestion, or direct skin contact. In biological laboratories, risks also include the potential for exposure to microorganisms that could result in infection and illness. The level of potential exposure to biological contaminants will in part determine the type of cleaning agent chosen. For example, an analytical laboratory primarily working with chemical agents might prefer 70% isopropanol, while a biochemical laboratory would use 70% ethanol to reduce contamination.

Secondarily, the cleaning agent selected must be able to fully remove contamination yet not damage the equipment. A more complete reference of appropriate cleaning agents for lab and contaminant type follows on pages 7 and 14.

Again, balances should always be cleaned after weighing potentially toxic reagents.



### Quick Tip: Lean LAB

Follow the 5S workplace organisation technique: the phase "shine" (and "set in order") recommends you divide the surroundings around your balance in a "waste & dirt" and a "clean" bench area. Strictly keep used tools in the "waste & dirt" area and place e.g. accessories like a printer in the "clean" area.

## 3. Is It Time to Clean My Balance?

Laboratories differ on how often a balance should be cleaned, depending on industry, application and frequency of use. Typically there are SOPs that specify the frequency for balance cleaning.

However, we recommend as a general rule that the balance should be cleaned immediately after every use or change of weighing substance.

Every user expects that the previous user has left the instrument clean. However, control is always better than trust. Therefore, before you start work, inspect the instrument in front of you. If the balance is obviously soiled, then immediate cleaning prior to use is required.

When handling potentially toxic substances, the balance must always be cleaned immediately after use. This avoids cross-contamination and exposure risk for the person who uses the instrument next.

## 4. Standard Balance Cleaning Procedures

### 1. Get ready: Protect yourself and prepare instructions.

- a) Wear appropriate personnel protective equipment (coat, goggles and gloves).
- b) Consult the operating instructions on how to disassemble and reassemble the removable parts of your balance.
- c) Consult the operating instructions or table 1 (see p. 7) on which cleaning methods and agents are recommended to clean the balance parts.

### 2. Switch off the balance display.

Unplugging the power is recommended but not necessary. If possible, leave the balance in its normal operating position, do not tilt it sideways and don't unplug connected peripherals.

### 3. Clean the area around the balance.

Use a tissue to remove any dirt surrounding the unit to avoid further contamination.

### 4. Disassemble all removable parts.

Depending on your balance model:

- a) Unlock and gently remove the draft shield panes;
- b) Remove the inner draft shield;
- c) Remove weighing pan, pan cover, pan support, wind ring and drip tray.

### 5. Clean the balance itself.

Use a lint-free cloth moistened with a mild cleaning agent to clean and remove any spilled material on the surface of the balance. First remove powder and dust, then sticky substances.

- a) For removal of powder or dust use a disposable tissue. Never blow; this could transport the dirt inside the balance.
- b) For removal of sticky substances use a damp lint-free cloth and mild solvent (isopropanol or ethanol 70%); avoid abrasive materials.
- c) Wipe away from the hole in the middle of the balance. Do not allow any substance to enter the balance's internal parts and do not spray or pour liquids on the balance. This might lead to damage of the weighing cell or other essential balance components.

### 6. Clean the removable parts.

Use a damp cloth or tissue and clean with a mild cleaning agent containing ethanol (e.g. a commercial window cleaner), or simply place them in the dishwasher.

### 7. Reassemble the balance.

Make sure the parts are correctly positioned, switch the balance on and check that it is working correctly. If completely switched off: Ensure enough warm-up time before first use (check the operating instructions for manufacturer's recommendation).

### 8. Ensure the balance is ready.

- a) Ensure that the air bubble is in the center of the marked circle, and take appropriate action to re-level if it is not;
- b) Calibrate with external weights or execute an internal calibration such as FACT;
- c) Place a test weight on the weighing pan and perform a routine test to check accuracy;
- d) Test accessories (e.g. make a test printout for printers).

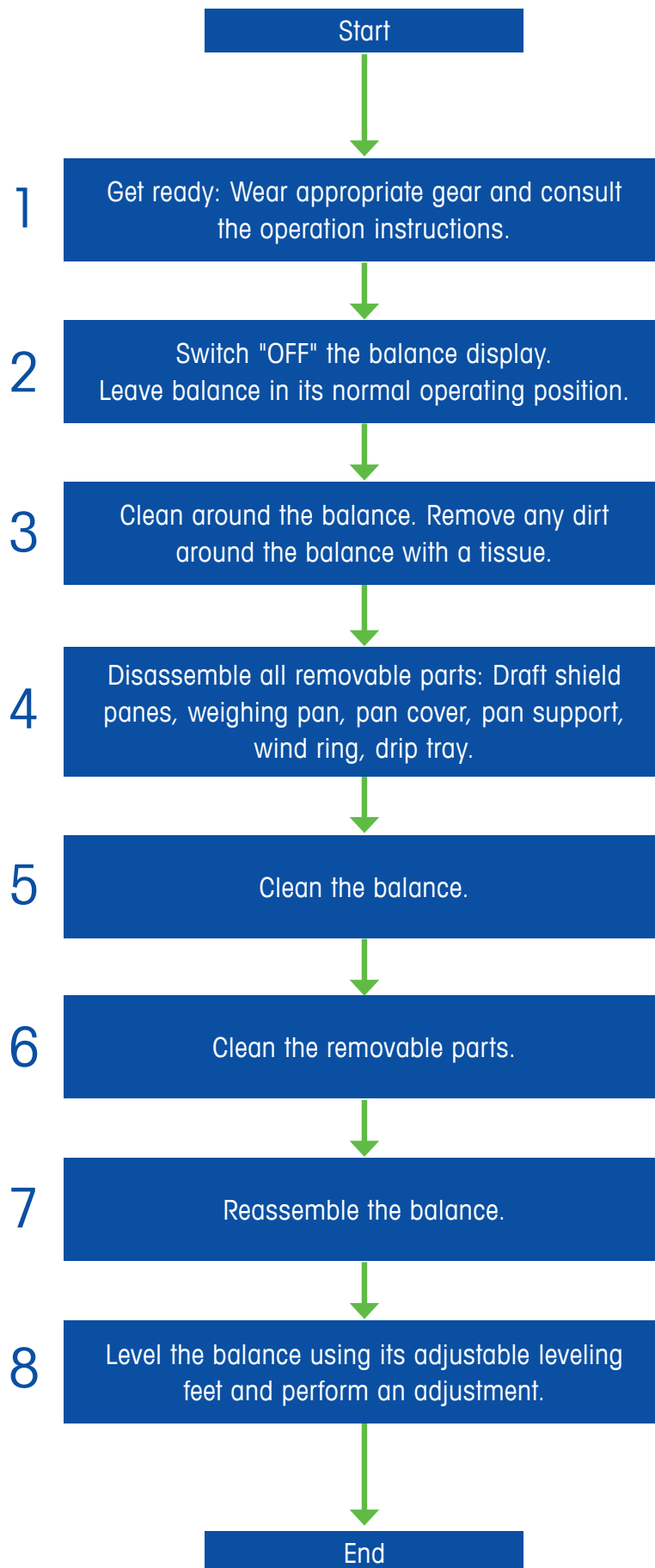

Figure 1: General balance cleaning procedure

## 5. Tips for Cleaning Your Weighing Instrument

### When easy cleaning is part of your balance design

METTLER TOLEDO balances are designed for easy cleaning. Materials used for the housing, terminal and weighing pan are durable and robust. Protective covers consist of Barex resins. Housings are typically die-cast aluminum, plastic, chrome steel and glass. Terminals are made of die-cast zinc, chrome and plastics, and grid weighing pans of chrome-nickel steel (X5CrNi18–10). Even with their robust design, however, certain precautions should be taken and appropriate agents used during cleaning procedures.

Notable exceptions are draft shields. Where included, draft shields can be taken apart and cleaned in dishwashers up to 80 °C (176 °F). Weighing pans and drip trays are removable and may also be cleaned in dishwashers (check the instruction manual of the respective balance).

Balances resist a wipe-cleaning or disinfection with alcohols-, and hydrocarbons. Exposure can occur for some minutes without damage. We recommend the use of alcohols as the disinfection agent of choice.

The following table on page 7 will detail cleaning recommendations for your METTLER TOLEDO balance. A reference for the balance parts and pieces follows on page 8.

### Quick Tip: Sterilizing of METTLER TOLEDO Balances

METTLER TOLEDO recommends the use of vaporized hydrogen peroxide. It is increasingly used as a standard to sterilize cleanrooms and fume hoods. Because it does not damage electronics and other devices, it should be considered a primary method for superficial sterilization of METTLER TOLEDO balances when necessary.

The following procedures are NOT recommended for METTLER TOLEDO balances, but are acceptable for weighing pans and drip trays:

- Dry heat;
- Steam autoclaving;
- Ionizing radiation;
- Ethylene-oxide (EO);
- Formaldehyde fumigation.



### Quick Tip: Protect Yourself

For all cleaning steps, work with standard laboratory personal protective equipment. Wear your lab coat, gloves, close-toed shoes and goggles.

## Recommendation on Cleaning Methods and Agents

		Cleaning Tools			Cleaning Agents						
		Paper Tissue	Brush	Dishwasher	Water	Acetone	Ethanol (70%)	Isopropanol (70%)	Hydrochloric acid (3–10%)	Sodiumhydroxide (0.1–1.0 M)	Peracetic acid (2–3%)
<b>Surrounding</b>	Lab bench or weighing table	✓	(R)	n.a.	R	(D)	✓	R	(D)	(D)	(D)
<b>Balance Housing</b>	Top housing	✓	(R)	–	R	–	R	✓	R	R	R
	Bottom housing	✓	(R)	–	R	–	R	✓	R	R	R
	Back housing	✓	(R)	–	R	–	R	✓	R	(R)	R
	Level indicator / level sensor / level bubble	✓	(R)	–	✓	–	(R)	(R)	R	R	R
	Feet	R	(R)	–	R	–	R	✓	R	R	R
<b>Balance Terminal</b>	Terminal	✓	–	–	✓	(R)	(R)	(R)	R	R	R
	Screen / display	✓	–	–	✓	(R)	R	R	R	R	R
<b>Balance Draft Shield</b>	Glass panes	R	(R)	✓	R	(R)	R	R	R	R	R
	Glass-free panes	R	(R)	–	R	–	✓	R	R	R	R
	Non-removeable handles and frames	✓	(R)	–	R	(R)	R	✓	R	R	R
<b>Weighing Area</b>	Draft ring element / wind ring	R	(R)	✓	R	–	(R)	(R)	R	(R)	R
	Weighing pan	✓	(R)	–	R	(R)	✓	R	R	R	R
	SmartGrid weighing pan	R	(R)	✓	R	(R)	R	R	R	R	R
	SmartPan weighing pan	R	(R)	✓	R	(R)	R	R	R	R	R
	Drip tray	R	(R)	✓	R	–	(R)	(R)	–	–	R
<b>Accessories</b>	Protective cover	✓	(R)	–	✓	–	R	R	R	R	R
	ErgoClips	✓	R	D	R	(R)	✓	R	R	R	R
	Antistatic Kit	✓	R	–	–	–	–	–	–	–	–

Table 1: Compatibility of balance parts to cleaning tools and agents or chemicals

✓ : Best recommendation by METTLER TOLEDO, can be used without limitation

R: Recommended by METTLER TOLEDO, can be used without limitation

(R): Partially recommended by METTLER TOLEDO (for selected balance lines only, please check the respective operating instructions; might also depend on your internal regulations.)

(D): Depending on the material used: individual durability and resistance to acid and alkali must be evaluated

–: Not recommended

## Balance Components

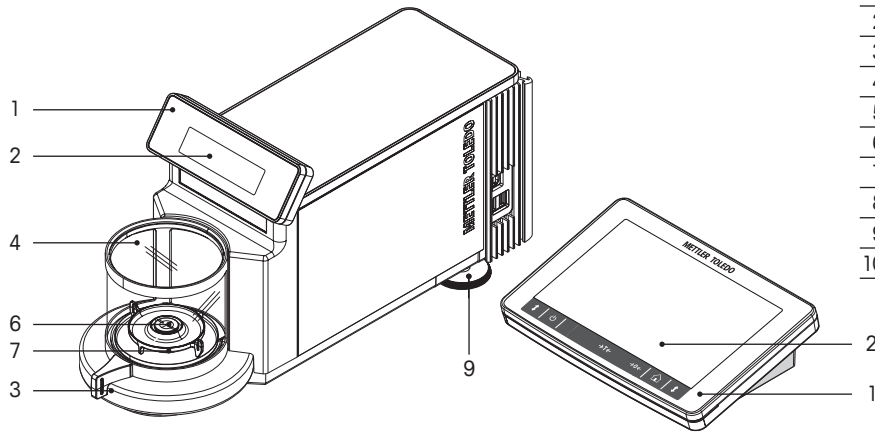

1	Terminal
2	Screen / display
3	Draft shield handles / frames
4	Draft shield glasses
5	Draft ring element / wind ring
6	Weighing pan / SmartGrid / SmartPan
7	Drip tray
8	Level / level sensor
9	Levelling screw / foot screws
10	Safety feet

Figure 2: XPR microbalance parts

### 0.005 mg – 0.1 mg

### 1 mg

### 0.01 g – 0.005 g

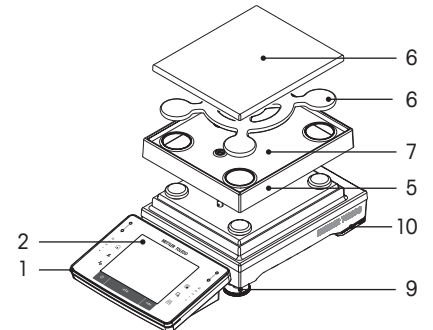
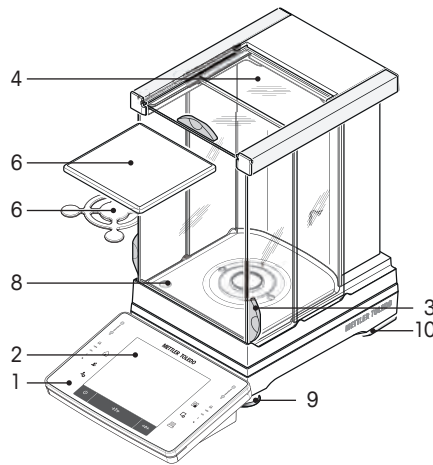
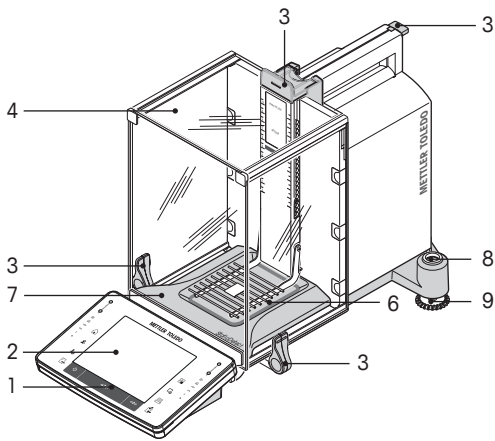

### 0.1 g – 1 g

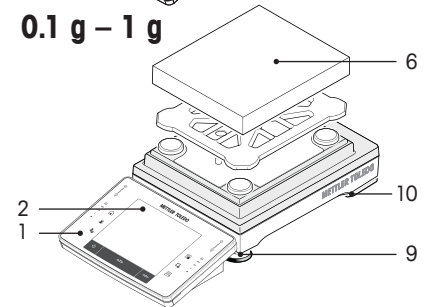
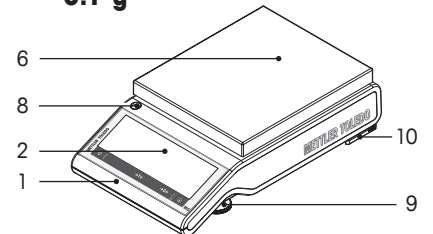
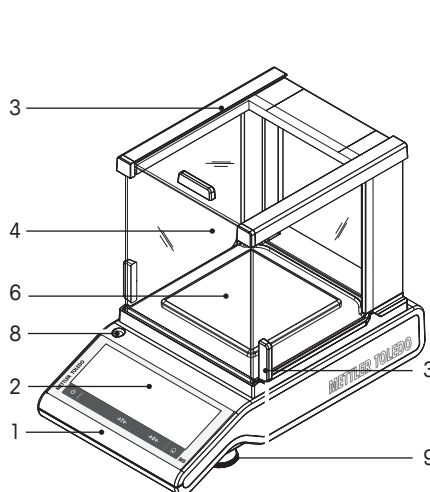
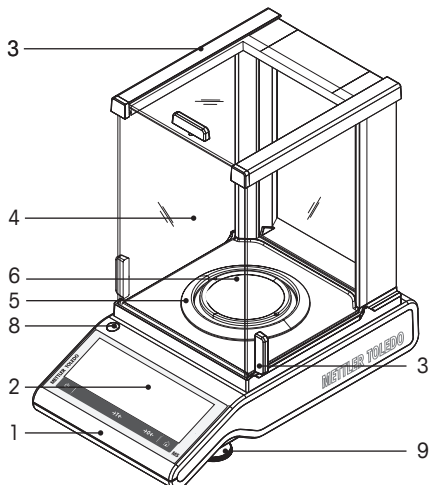

Figure 3: XPE analytical and precision balance parts

### 0.1 mg

### 1 mg

### 0.1 g



### 10 mg

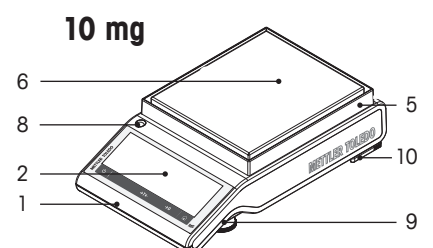

Figure 4: MS-TS analytical and precision balance parts



## 6. Avoid Making Your Balance Dirty

Here are five solutions from METTLER TOLEDO that will help you prevent your balance from getting dirty in the first place.

### 1. Use a balance designed to avoid dirt

When evaluating a new balance, keep an eye on gaps and shoulders in the design and check if the draft shield can be dismantled without tools. Better yet, determine if it can be removed in just a few steps and put in the dishwasher. This can help ensure easy clean-up when spills occur.

In METTLER TOLEDO XPE and XS lines, there are special “grid” weighing platforms (SmartGrid and SmartPan) which ensure that spilled substances fall into the tray underneath, and do not interfere with the weighing result mid-process. Both pan and tray can be removed and put in the dishwasher for thorough cleaning after weighing is complete.



Figure 5: METTLER TOLEDO XPE balance features that contribute to a clean weighing experience

## 2. Avoid touch contamination or soiling

A balance that allows touchless operation – achieved through a built-in functionality, an optical hand-sensor, or addition of a foot switch – can help prevent soiling. This can be especially helpful when working with toxic substances.

A balance that allows you to detach the balance terminal and move it away from the weighing platform can also help avoid contamination, as can the use of a secondary display or display stand.

Finally, if possible, use fewer cables, as these offer an excellent way to trap undesirable dirt and dust around the weighing unit. Bluetooth may be a better option for data transfer in areas where cleanliness is of utmost importance.



Figure 6: Operate the balance without touching it: Add an optical hand-sensor, configured to open the draft shield door, to tare or to print results simply with a wave of your hand.

### Quick Tip: Create Contrast

When working with a white, powdery substance, change the XPE/XS analytical balance base plate (drip tray) with a grey one to clearly see spills and residue. Both trays simply lift out for easy cleaning in the dishwasher.

Additionally, we recommended to use a UV-lamp for a quick check if a balance and its surroundings are clean.



### 3. Protect the balance in-use

Replaceable protective covers and mats safeguard your balance in-use from soiling, prevents scratches and ensures a long instrument lifetime.



#### a) Protective covers

Exchangeable protective covers add an additional layer of protection for the balance. Safeguarding the balance from dirt and hazardous or sticky substances, they can be easily thrown away and replaced when soiled. The protective covers help protect the touchscreen and the terminal or the whole balance from spills or dust, without interfering with balance operation.



#### b) Protection mat

For MS, ML and ME precision balances a separate pan protection mat is available. This mat absorbs minor liquid spills and guides the user to position the tare container centrally on the weighing pan. The pan remains protected from scratches.

### 4. Safe dosing

Sample and standard preparation require substance transfer from the original container to the preparation vessel, such as volumetric flask, test tube, and other. All material transfers bear a risk of spills and potentially create a need for cleaning.



#### a) Avoid scattering during transfer

Simplify dosing of powdery substances into flasks, with the METTLER TOLEDO SmartPrep weighing funnel and say goodbye to traditional weighing-paper. The disposable funnel is a single-use consumable used to weigh-in powders prior to volumetric sample preparation. Thanks to its antistatic material, powder is not scattered during weigh-in nor is it scattered during transfer to the flask since the funnel fits most flask sizes. The substance can be rinsed directly into the flask.



#### b) Safely dose directly into tare containers

One-step dosing directly into the tare container reduces transfer steps, eliminates errors and substantially reduces contamination risks. METTLER TOLEDO has designed various ErgoClip holders for many different application and tare containers. These can be used to support volumetric flasks, vials, tubes, titration beakers and filters. ErgoClip holders fit all XPE and XS analytical balances with a Smart-Grid weighing pan.



### c) Secure dangerous powders

When working with toxic substances, the cleaning might be insufficient and the affected area or weighing instrument must be decontaminated to eliminate the exposure risk to operators. METTLER TOLEDO has developed the automated powder dispensing – simply upgrade your XPE analytical balance with a powder module for automatic dosing of powders. The substance is contained in the dosing head, completely eliminating the contact of the operator with the dosed substance.



Figure 7: ErgoClip holders stabilize the tare container in the XPE and XS analytical balance to enable one-step direct dosing and therefore eliminate sample-transfer errors and scattering

## 5. Protect the balance when it is not in use

They may be simple, but they work: Dust covers are excellent barriers against environmental contaminants like dust and moisture. They also protect against accidental soiling or spills. All covers from METTLER TOLEDO are designed to be chemically resistant and easy to place and remove.



Figure 8: Covers provide protection from dust and moisture when balances are not in use

## 7. Summary

Cleaning a balance is important to ensure accurate results and promote long equipment life. It also has a direct impact on operator safety.

Cleaning can be easy with an understanding of methods and cleaning agents.

Ideally, laboratory SOPs dictate the schedule for balance cleaning. After weighing, make sure the balance is clean for the next operator to prevent cross-contamination. Balances must be thoroughly cleaned after weighing potentially toxic substances to prevent exposure risk.

Use standard laboratory personal protective equipment when cleaning a balance. Turn off balances before cleaning. Use a tissue to remove substance from the surrounding bench area. Dismantle the draft shield and either wipe the glass panes clean or place in the dishwasher. Clean the balance using a moistened cloth and the mildest cleaning agent that will completely remove the substance. A list of suitable cleaning agents can be found on page 7.

It is critical to wipe any dirt or liquids away from the center hole of the balance, underneath the weighing pan. No substances should be allowed to fall into the weighing cell. Additionally, to ensure accurate ongoing operation, balances should always be levelled after cleaning.

Certain solutions help you avoid spillage during weighing. Anti-static SmartPrep funnels avoid spills and make substance transfer easy. Grid weighing pans (SmartGrid and SmartPan) allow substances to fall into the tray so they do not disrupt weighing. ErgoClip holders allow direct one-step dosing into the designated tare container. Upgrade your analytical balance with a powder dosing module to secure your powders and dose directly into tare containers.

Above all, a clean balance protects you from cross-contamination and ensures that you and your team are not exposed to potential harmful substances, making weighing safer for your entire laboratory.

## Appendix: Types of Cleaning Agents and Surface Treatments

Cleaning agents consist of a large array of different chemicals and substances. They can be classified into different types based on their consistency and function.

Type	pH	Examples	Use	Surfaces	Hazards, Restraints
<b>Strong alkali</b>	14	<b>Sodium hydroxide</b> (caustic soda), <b>potassium hydroxide</b> (caustic potassa)	Medical and biological cleaner and disinfectant. Destroys microbes, viruses, endotoxins. Removes blood, saliva, bone- and tissue residues. Decomposes proteins. Dissolves greases/fats and oils, resinified and tarry residues; polishing and grinding residues; markings, labels, fingerprints and dust.	Labware and medical instruments from metal, alkali-resistant glass, porcelain, ceramic and alkali-resistant plastic materials. Is also used for pipe/drain cleaning.	Severely corrosive, caustic to skin, eyes and lungs. Flammable when in contact with organic solvents. Not suitable for aluminum, magnesium and alloys of light metals.
<b>Medium to strong alkali</b>	13	<b>Sodium hypochlorite</b> (bleach, NaOCl)	Common and most economic disinfectant used in households, and biological and medical laboratories. Removes bacteria, yeasts, mold, algae and viruses.	Glass labware, medical and dental instruments, alkali-resistant glass and plastics.	Irritation, tearing, headache, breath shortness, nausea. Corrosive to stainless steel and damaging to plastic surfaces.
<b>Medium alkali</b>	12	<b>Sodium carbonate</b> (wash soda)	Universal cleaner and key component of laundry soaps and household cleaners. Removes fat, grease, lacquer, paint, greasy stains like fingerprints, light grease and lubricant residues, dust and dirt and lime soap leftovers.	Glassware (calibrated pipettes, burettes, measuring cylinders and volumetric flasks); instruments of volumetric analysis from stainless steel, glass, ceramics and plastic materials.	Slightly corrosive – for items made of aluminum, magnesium and alloys of light metals check for resistance first.
<b>Mild alkali</b>	9-11	<b>Ammonia, sodium bicarbonate</b>	Removes minor soils, emulsions, greases and oils, greases for ground-glass joints, weakly resinified residues, markings, labels, fingerprints and dust, lime soaps and lime residues.	Labware from metal, glass, porcelain, ceramic and plastic materials.	Toxic (vapors) and eye-irritating. Not suitable for aluminum, magnesium and alloys of light-metals.
<b>Neutral</b>	6-8	<b>Buffering solutions</b> e.g. containing carbonic acid or carbonate	Cleaner for sensitive materials, such as aluminum and light metals. Removes emulsions, residues of markings and labels, Ca- and Mg-bound contaminations (lime soaps), light greases and oils, fingerprints and dust.	Labware from metal (incl. aluminum and its alloys), glass, ceramic, mineral and plastic materials.	For magnesium alloys check for resistance first.

Type	pH	Examples	Use	Surfaces	Hazards, Restraints
Mild acid	4–5	<b>Acetic acid</b> , peracetic acid, gluconic acid, levulinic acid, citric acid, oxalic acid	Controls mineral deposits, softens water and therefore enhances the cleaning effectiveness. Removes Ca- and Mg-bound contaminations (lime, lime soaps), oxides and tarnish of brass, bronze (colored metals), light mineral oils and greases, emulsions, fingerprints, dust.	Labware from metal (incl. aluminum and its alloys), glass, ceramic and plastic materials.	Slightly corrosive. Check magnesium alloys and acid sensitive glassy materials for resistance first. Not suitable for removing vegetable and animal fat and oil.
Medium acid	2–3	<b>Formic acid</b>	Disinfectant destroying bacteria. Effective descaling agent and removes metal corrosion. Biodegradable.	Cleaning and descaling of equipment and tanks, corrosion removal, wine casks, dairies.	Low toxicity; can be caustic when highly concentrated and may cause skin allergy.
Strong acid	<1	<b>Hydrochloric and perchloric acid</b> hydrofluoric acid, phosphoric acid, sulfuric acid	Removal of very tenacious contamination, dissolves surface mineral deposits, Ca- and Mg-bound contaminations (lime, lime soaps); metal oxides (rust), flux- and inorganic residues, mineral oils and greases, emulsions, fingerprints and dust.	Labware, medical and dental instruments and work pieces made from stainless steel, glass, ceramics and plastic materials.	Corrosive to concrete, metals, fabric, and skin. Damage of painted surfaces, wood, limestone and marble. Not suitable for aluminum and light metal alloys. Check acid-sensitive plastic and glassy materials before using.
Organic solvents		<b>Ethanol, Isopropanol</b> , aldehydes, ketones, petroleum products, turpentine	Degreases by dissolving fat and oil, dry cleaning and industrial degreasing (removes organic and inorganic soils). Removes paints, inks and adhesives.	Lubricated instrument parts, motorized elements e.g. shafts, spindles, springs, gears.	Flammable, reactive (property varies with solvent type). Often volatile; vapors irritating to respiratory tract, eye and skin irritation on direct contact.
Soaps, surfactants and detergents		<b>Soaps</b> (sodium or potassium salts of triglyceride and fatty acids)	All-purpose cleaners used for personal cleaning and laundry, dishwashing and household cleaning. Emulsify fat, oil and grease. Removes hard water deposits, soap scums, rust stains, grime, mold, and tarnish from metal surfaces. Also effective as bactericide (disinfectant).	Glass, tile, metal, sinks, tubs, ovens, carpets, drains.	Generally low risk to human health, particularly when diluted. Refer to the caution/warning label placed on the particular product.

Table 2: Types of cleaning agents and surface treatments

# Benefit From Our Weighing Expertise

With decades of experience in laboratory weighing, METTLER TOLEDO can offer you a wide range of online learning resources. Take advantage of our expertise to enhance your weighing know-how and make the most of your balance. Check out the documentation on our internet pages for a range of relevant materials.

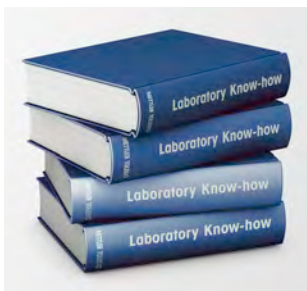

## Laboratory Expertise

This portal of laboratory knowledge offers a wealth of free information and advice. Learn from experts about a range of topics, such as:

- Calibrating your weighing devices
- Electrostatic effects on weighing
- USP Revisions

▶ [www.mt.com/lab-expertise](http://www.mt.com/lab-expertise)



## Expert Library

A one-stop portal for knowledge resources: White papers, guides, videos, webinars and more.

- Educational papers with tips and tricks
- White papers with expert knowledge
- GWP® The Standard – Science Based Weighing

▶ [www.mt.com/library](http://www.mt.com/library)

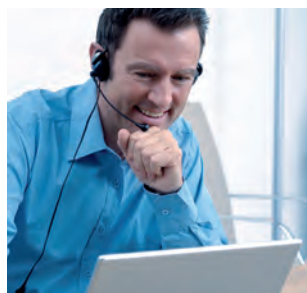

## E-learning Courses

Learn directly from our weighing experts. It's easy to register.

For starters, we recommend:

- External Influences and Cleaning
- Safe Weighing under Harsh Conditions
- Balance Routine Testing

▶ [www.mt.com/lab-elearning](http://www.mt.com/lab-elearning)