

Fabrication materials: Stainless Steel 304L with electro-polished finish

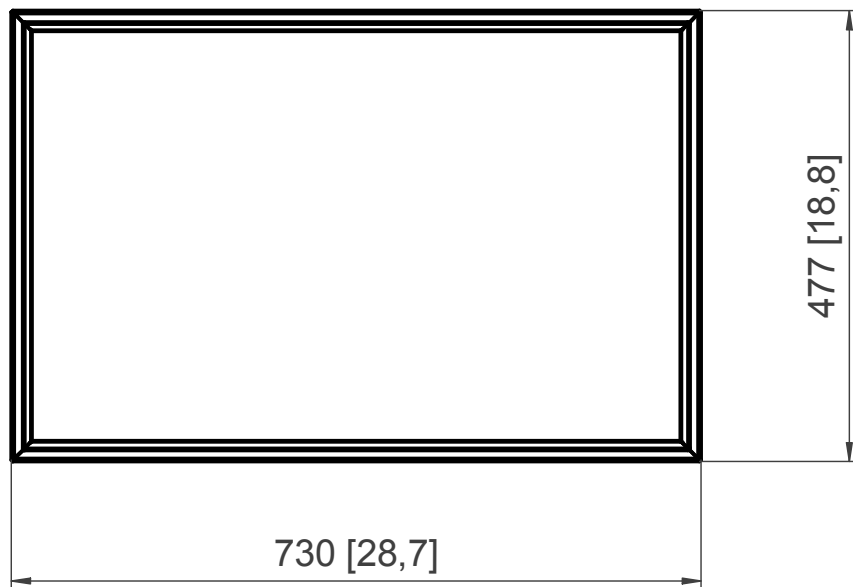
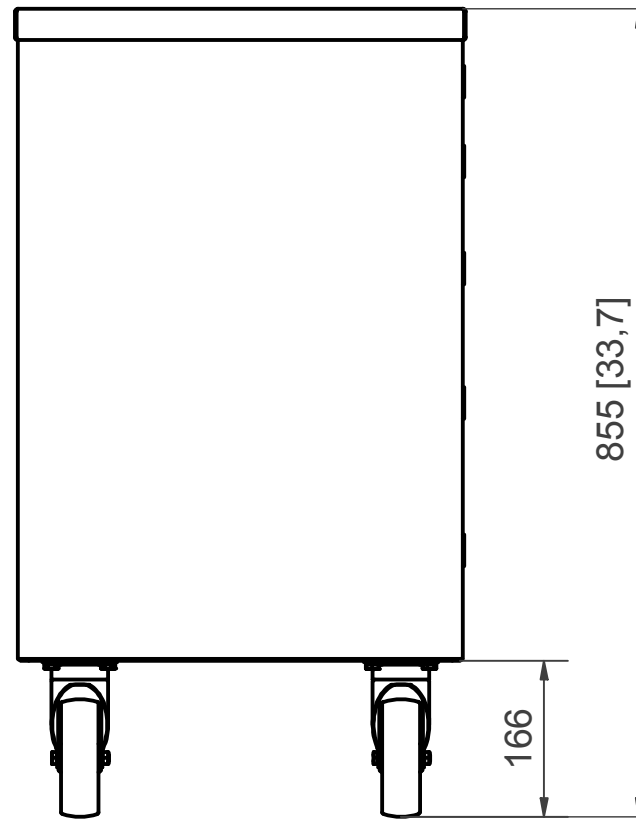
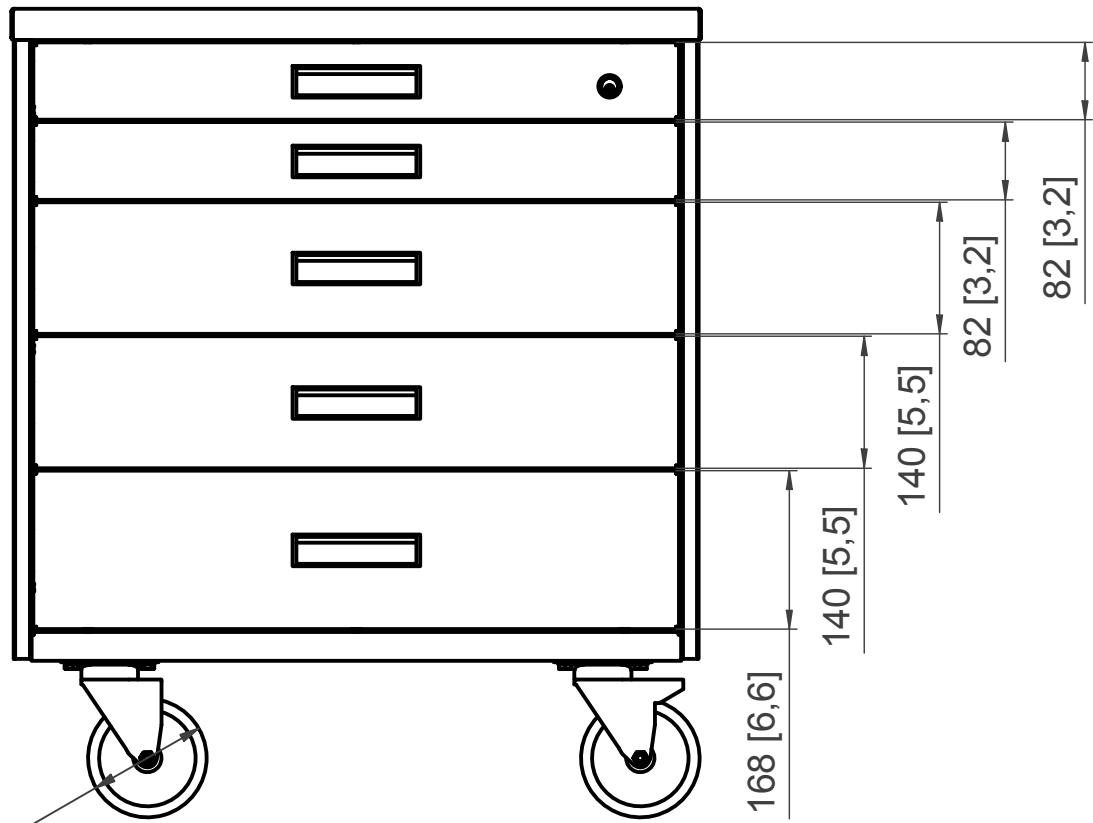

77 kg	VARIATION IN DIMENSIONS WITHOUT TOLERANCE IND. DIN 7168		<b>PalbamClass</b> EN HAROD IHUD	EUROPE PROJ 
	BREAK EDGES	STATUS		
ALL RIGHTS STRICTLY RESERVED USE, REPRODUCTION OR ISSUE TO THIRD PARTY IN ANY FORM WHATEVER IS NOT PERMITTED UNLESS AUTHORIZED IN WRITING BY THE PROPRIETOR PalbamClass IL-18960 EN-HAROD IHUD-ISRAEL.	0.3x45		Tool Cart-5 Drawers <b>TOOLCART</b>	
	INNER RADIUS	SURF. ROUGH. PER ISO 1302	DWG. No.	PCCT0702-000
	DATE	NAME	REV	B
	DESG	19/08/2004	Alexey	SCALE
APPR			SIZE	A3
CONTROLLED COPIES OF THIS DOCUMENT HAVE A RED ISSUE DATE STAMP, THESE COPIES WILL BE UPDATED BY RICOR INFORMATION SYSTEM. ANY OTHER COPY IS NOT CONTROLLED AND THEREFORE NOT UPDATED. PLEASE CHECK WITH INFORMATION SYSTEM FOR VALIDITY OF DOCUMENT.			SHEET	1 / 1