

ABT-VS-LP-49-TS

Product Description

These premium touchscreen refrigerators offer precise temperature control and advanced digital monitoring, ideal for clinical and research settings. They feature variable speed compressor technology for exceptional performance and energy efficiency. Experience an intuitive color touchscreen controller, offering multi-layered access and data logging capabilities. Protect your samples with forced draft air circulation and customizable alarms with remote contacts. Also enjoy the benefit of natural, hydrocarbon refrigerants for energy savings and a greener laboratory footprint. This refrigerator is constructed with durable powder-coated steel, self-closing glass doors, a keyed access lock, LED interior lighting, and adjustable interior shelving. Also included is a comprehensive 3-year parts and labor warranty with a generous 7-year compressor warranty to protect your investment. With these refrigerators, you'll increase performance and maximize efficiency in your lab.

Images



Certifications



General Description and Application

Storage capacity (cu. ft)	49 Cu. Ft.
Door	Two (2) swing glass doors, self-closing, right hinged, not reversible, magnetic door gasket
Shelves	Eight (8) adjustable shelves (adjustable in 1/2" increments)
Mounting and installation	Swivel casters - locking front casters
Interior lighting	LED interior lights are safety shielded and switch controlled
Airflow Management	Forced draft air circulation - Patented air flow technology
External probe access	Probe access port (3/4") on rear wall
Insulation	Cabinet is foamed-in-place with EPA compliant high density urethane foam
Exterior materials	White powder coated steel
Access control	Keyed door lock; compatible with optional digital lock (including Pyxis, Omnicell, and AcuDose RX)
General warranty	Three (3) years parts and labor warranty
Compressor warranty	Seven (7) years compressor warranty
Product Weight (lbs)	452
Shipping Weight (lbs)	545
Rated Amperage	3 Amps
Power Plug/Power Cord	NEMA 5-15 plug
Facility Electrical Requirement	110 - 120V AC, 15A breaker, NEMA 5-15 receptacle
Agency Listing and Certification	ETL, C-ETL listed. Meets or exceeds Energy Star v2.0 for Laboratory Refrigerators. Official listing pending - see energystar.gov

Refrigeration System	
Compressor	Hermetic, Variable speed
Refrigerant	EPA SNAP compliant R600a Isobutane (Hydrocarbon natural refrigerant)
Condenser	Tube and grid, high efficiency fan forced air
Evaporator	Fin and tube, high efficiency fan forced air
Defrost	Off-cycle defrost, no heat added

Controller, Configuration, Alarms and Monitoring	
Controller technology	Microprocessor with color touchscreen (8in) input and display, C/F switchable, resolution is 0.1C/0.2F
Noise pressure level (dBA):	40 dBA or less installed
Display technology	8" touchscreen featuring: Security and Access: Multi-Level Password Protection: User, Supervisor, and Admin roles for access and control. Advanced Controls: Customizable Passwords/PINs: Ensures tailored access for your team. Calibration Adjustments: Fine-tune temperature offsets for precise measurements. Visual and User Interface: Intuitive Touch Screen: Pinch-to-zoom, scrollable graphs, and customizable display options. Adjustable Display Settings: Screen brightness, real-time temperature comparison to alarm points.
Stability - simulator ballast (°C):	+/- 0.2
Average heat rejection (BTU/h):	630 BTU/h
Max temp variation - cabinet air (°C):	+/- 1.0 °C
Adjustable Temperature Range	2°C to 15°C
External alarm connection	Remote alarm contacts
Digital Communication	4-20mA Output
Battery Backup:	High capacity 12V battery for controller temperature and alarm display and logging only, no cooling active
Energy consumption (KWh/day):	2.5 KWh/day *meets Energy Star v2.0 for Laboratory Refrigerators
Display probe	Product simulator bottle with glass bead media
Pull down time to nominal operating temp: Alarms	< 40 min (empty)
Disclaimer(s):	Audible & Visual Alarms: Customizable sounds and volumes; silent mode with visual persistence. Alarm Delays: Adjustable settings for door, temperature, and power loss alarms to prevent nuisance alerts. Ring-Back Functionality: Audible alarms re-engage after a preset delay if the condition persists.
Performance Note	Refrigerator requires a minimum 2" of clearance at back and sides of the unit for proper ventilation
	Max temperature variation based on an empty chamber at steady state using 15 bare (unweighted) thermocouple probes. Product loading, door openings, and ambient conditions will affect performance. Stability of simulator ballast based on bottle probe provided with the unit located center of empty chamber at steady state, no door openings

Dimensions					
	Width (in.)	Depth (in.)	Height (in.)	Door Swing (in.)	Total open Depth (in.)
Exterior	54"	34.75"	81.75"	23.375"	58.125"
Interior	49.25"	27.5"	48.75"		

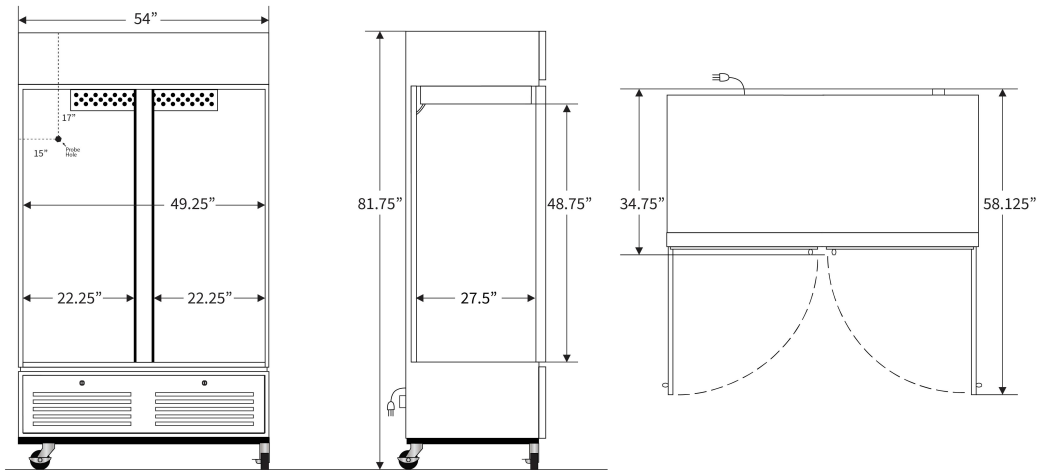

Contact		
Customer Service	800-648-4041 Option 3	customerservice@horizonscientific.com
Technical Service	800-648-4041 Option 5, Parts Option 4	technicalservice@horizonscientific.com

Rev_11.14.2025