

## ABT-VS-LP-49

### Product Description

These premier laboratory refrigerators are engineered with variable speed technology for exceptional efficiency and performance in clinical and research environments. They feature precise microprocessor temperature control and variable speed compressor technology. Enjoy low energy consumption and natural hydrocarbon refrigerants for cost-savings and energy efficiency. Security and monitoring features include a keyed door lock and comprehensive alarms with remote alarm contacts. The cabinet is built with durable powder-coated steel, self-closing glass doors, safety-shielded LED lighting, and adjustable interior shelving to enhance your workflow. This model delivers optimal temperature stability and includes a 2-year parts and labor warranty with a generous 7-year warranty on the compressor. These premier refrigerators are designed to increase performance and efficiency in your lab.

### Images



### Certifications



### General Description and Application

Storage capacity (cu. ft)	49 Cu. Ft.
Door	Two (2) swing glass doors, self-closing, right hinged, not reversible, magnetic door gasket
Shelves	Eight (8) adjustable shelves (adjustable in 1/8" increments)
Mounting and installation	Swivel casters - locking front casters
Interior lighting	LED interior lights are safety shielded and switch controlled
Airflow Management	Forced draft air circulation - Patented air flow technology
External probe access	Probe access port (3/4") on rear wall
Insulation	Cabinet is foamed-in-place with EPA compliant high density urethane foam
Exterior materials	White powder coated steel
Access control	Keyed door lock; compatible with optional digital lock (including Pyxis, Omnicell, and AcuDose RX)
General warranty	Two (2) years parts and labor warranty
Compressor warranty	Seven (7) years compressor warranty
Product Weight (lbs)	448
Shipping Weight (lbs)	540
Rated Amperage	3 Amps
Power Plug/Power Cord	NEMA 5-15 plug
Facility Electrical Requirement	110 - 120V AC, 15A breaker, NEMA 5-15 receptacle
Agency Listing and Certification	ETL, C-ETL listed. Meets or exceeds Energy Star v2.0 for Laboratory Refrigerators. Official listing pending - see energystar.gov

Refrigeration System	
Compressor	Hermetic, Variable speed
Refrigerant	EPA SNAP compliant R600a Isobutane (Hydrocarbon natural refrigerant)
Condenser	Tube and grid, high efficiency fan forced air
Evaporator	Fin and tube, high efficiency fan forced air
Defrost	Off-cycle defrost, no heat added

Controller, Configuration, Alarms and Monitoring	
Controller technology	Microprocessor temperature controller with variable frequency compressor control, C/F switchable, resolution is 0.1C/0.2F
Noise pressure level (dBA):	40 dBA or less installed
Display Technology	Digital Temperature Display
Average heat rejection (BTU/h):	< 570 BTU/h
Max temp variation - cabinet air (°C):	+/- 1.5 °C
Stability - simulator ballast (°C):	+/- 0.3
Adjustable Temperature Range	2°C to 15°C
External alarm connection	Remote alarm contacts
Battery Backup:	For controller temperature display and alarms only, no cooling active
Energy consumption (KWh/day):	<2.2 KWh/day *meets Energy Star v2.0 for Laboratory Refrigerators
Display probe	Product simulator bottle with glass bead media
Pull down time to nominal operating temp	< 40 min (empty)
Alarms:	Audible and visual high/low temperature alarms, remote alarm contacts, sensor error alarm, power failure alarm, door ajar alarm
Disclaimer(s):	Refrigerator requires a minimum 2" of clearance at back and sides of the unit for proper ventilation
Performance Note	Max temperature variation based on an empty chamber at steady state using 15 bare (unweighted) thermocouple probes. Product loading, door openings, and ambient conditions will affect performance. Stability of simulator ballast based on bottle probe provided with the unit located center of empty chamber at steady state, no door openings

Dimensions					
	Width (in.)	Depth (in.)	Height (in.)	Door Swing (in.)	Total open Depth (in.)
Exterior	54"	34.75"	81.75"	23.75"	58.125"
Interior	49.25"	27.5"	48.75"		

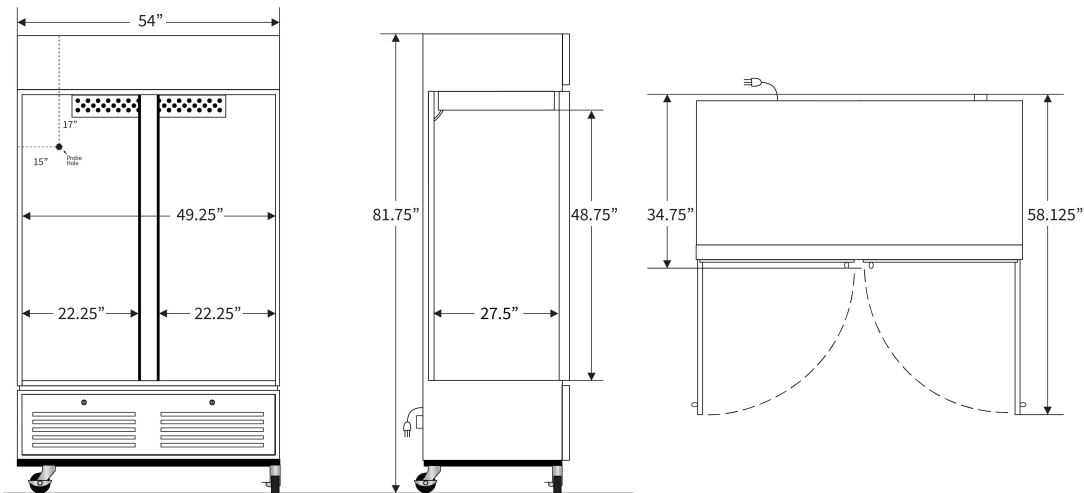

Contact		
Customer Service	800-648-4041 Option 3	<a href="mailto:customerservice@horizonscientific.com">customerservice@horizonscientific.com</a>
Technical Service	800-648-4041 Option 5, Parts Option 4	<a href="mailto:technicalservice@horizonscientific.com">technicalservice@horizonscientific.com</a>

Rev\_11.14.2025