



GENERAL SPECIFICATIONS

MATERIAL:	Polypropylene Homopolymer
COATING:	None
COLOR:	Natural
GRADUATION MARKS:	2.50ul
RACK CONFIGURATION:	Multichannel (8x12)
TEMPERATURE RANGE:	-80°C to 120°C
AUTOCLAVABLE:	121°C at 15 psi, 15 min.
AUTOMATION COMPLIANT:	No
WORKING VOLUME:	10ul

CRITICAL DIMENSIONS

LENGTH (OVERALL):	31.65mm
COLLAR HEIGHT:	3.80mm
BASE (OD):	6.00mm
DISPENSING (ID):	0.45mm
DISPENSING (OD):	0.75mm

PACKAGING CONFIGURATIONS

PACKAGING QUANTITY (CS):	96/Rack; 10 Racks/Unit; 5 Units/Case
CASE DIMENSIONS (IN.):	19 x 10.75 x 13.25
CASE WEIGHT (LBS.):	14.65

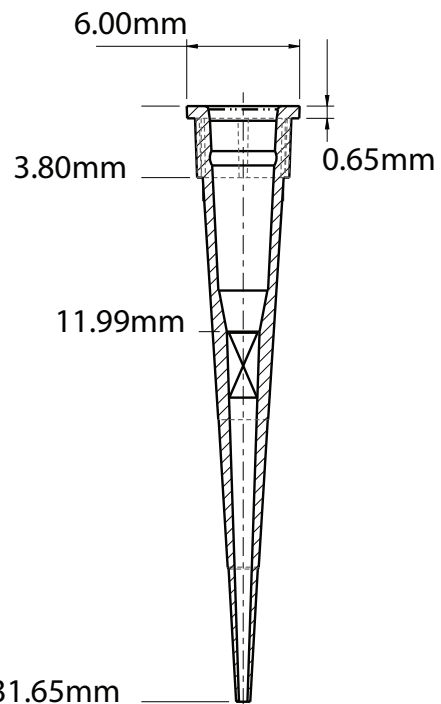

FT10G-H96-NS

STORAGE

Keep out of sunlight. Store in a cool dry place. Keep away from sources of ozone or ignition.

